

# KIA PV5 Passenger

5-Sitzer / 5-seater

51,5 kWh

MAX.  
≈ 2.600 kg





Rollstuhlgerechter Umbau von AMF-Brunns / WAV conversion by AMF-Brunns

## Originalboden / Original Floor

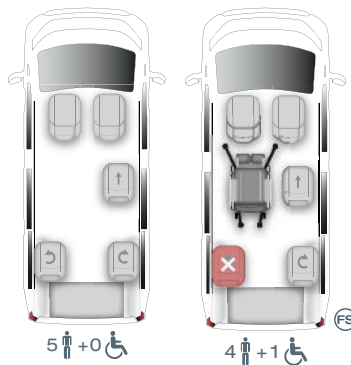
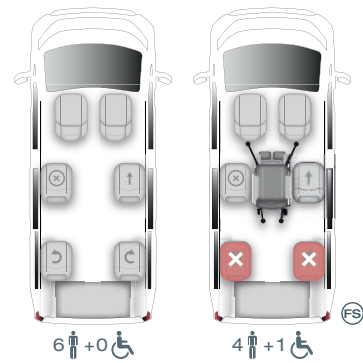
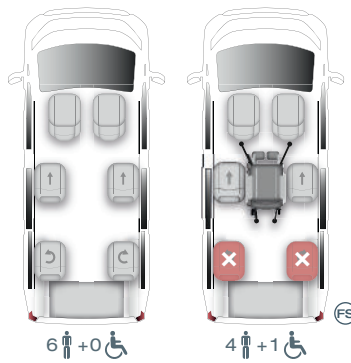
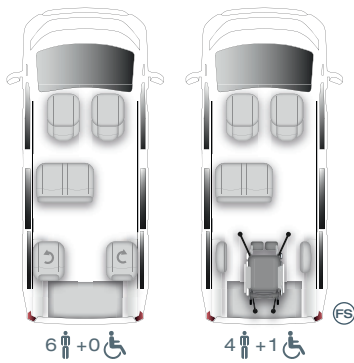
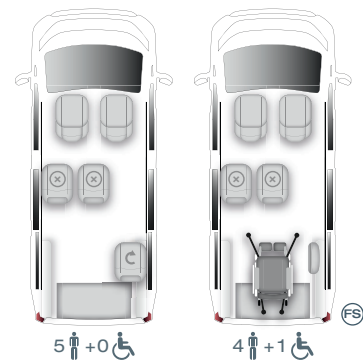
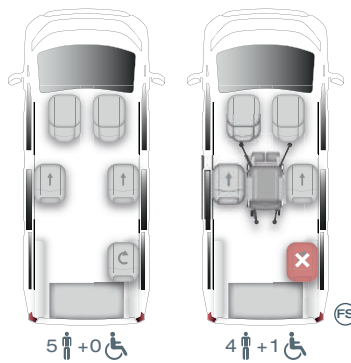
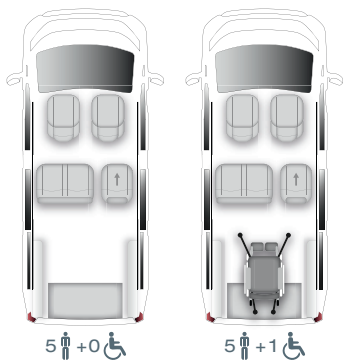
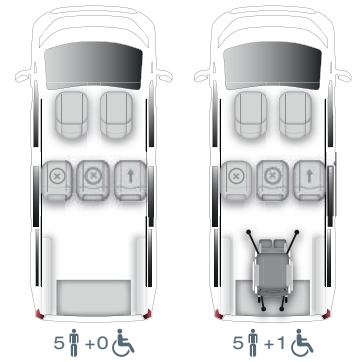
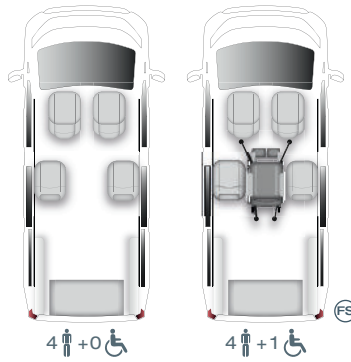
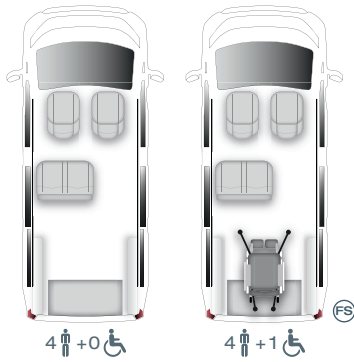
## Smartfloor Revolution

## Smartfloor



-  (Bei-)Fahrsitz / (Co-)driver's seat
-  Original 2er-Sitzbank / Original 2-seater bench
-  Klappbarer Einzelsitz / Fodlable single seat
-  Dreh- und klappbarer Einzelsitz / Swivel and folding single seat
-  Herausnehmbarer Einzelsitz / Removable single seat

 Sitz darf bei Rollstuhlbeförderung nicht besetzt werden (abhängig von Nutzlast und ZGG) / Seat must not be occupied when transporting a wheelchair (depending on payload and gross vehicle weight).

 FutureSafe optional erhältlich. Wenn Rollstuhl in 2. Reihe, kein Dreh-Klappsitz in 3. Reihe links. / FutureSafe available as an option. If wheelchair in 2nd row, no tip & fold seat in 3rd row on the left.

**Achtung:** Die abgebildeten Varianten sind abhängig von Nutzlast und ZGG. Die gewünschte Sitzvariante bedarf der vorherigen Prüfung. Änderungen vorbehalten.  
**Caution:** Seating arrangements shown depend on payload and gross vehicle weight. The desired seating option requires prior approval. Subject to change without notice.



www.amf-brunns.de

# KM PV5 Passenger

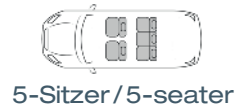

5-Sitzer/5-seater



71,2 kWh



≈ 2.600 kg

Rollstuhlgerechter Umbau von AMF-Brunns / WAV conversion by AMF-Brunns

## Originalboden/Original Floor

## Smartfloor Revolution

## Smartfloor

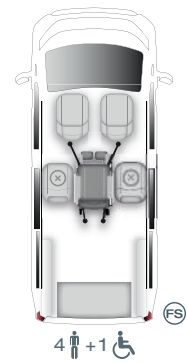
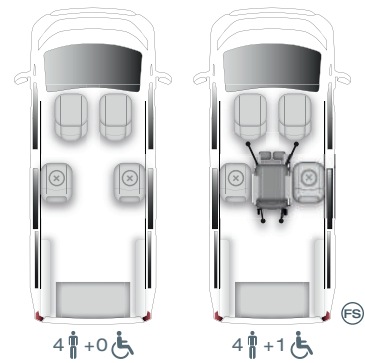
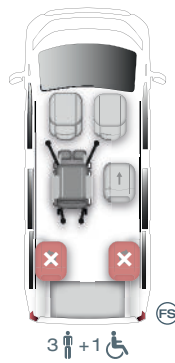
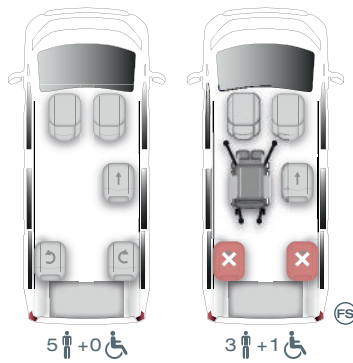
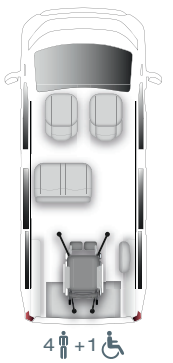
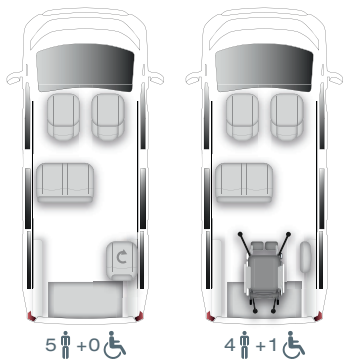
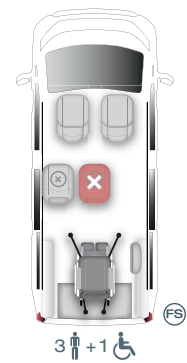
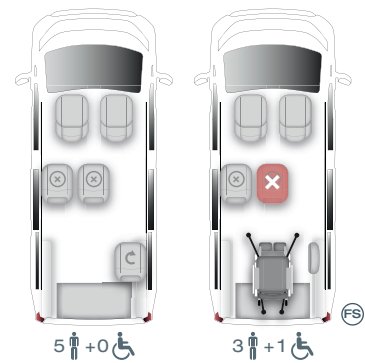
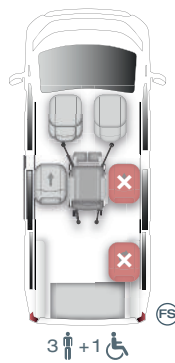
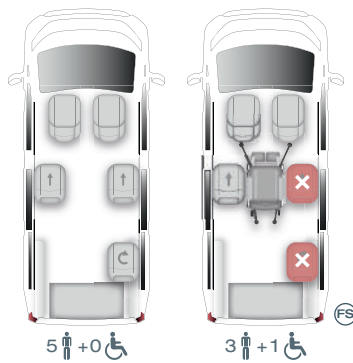
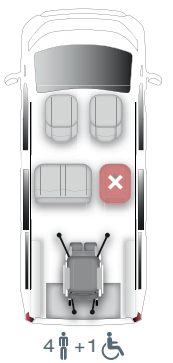
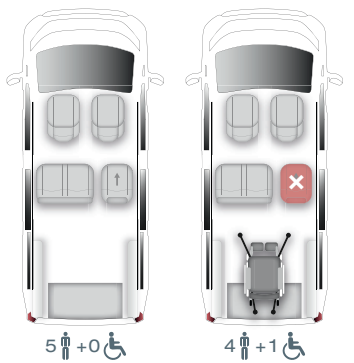
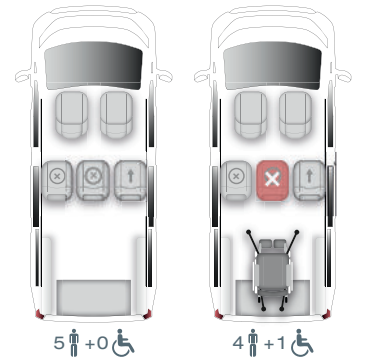
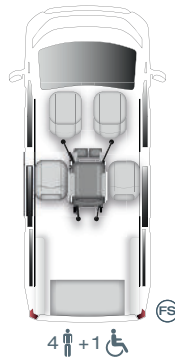
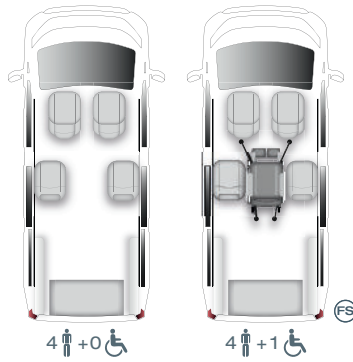
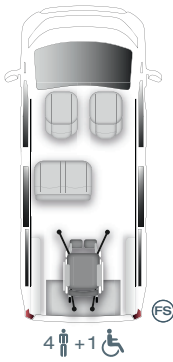
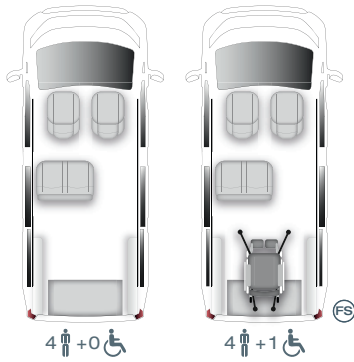

- (Bei-)Fahrsitz / (Co-)driver's seat
- Original 2er-Sitzbank / Original 2-seater bench
- Klappbarer Einzelsitz / Fodlable single seat
- Dreh- und klappbarer Einzelsitz / Swivel and folding single seat
- Herausnehmbarer Einzelsitz / Removable single seat
- Sitz darf bei Rollstuhlbeförderung nicht besetzt werden (abhängig von Nutzlast und ZGG) / Seat must not be occupied when transporting a wheelchair (depending on payload and gross vehicle weight).
- FutureSafe optional erhältlich. Wenn Rollstuhl in 2. Reihe, kein Dreh-Klappsitz in 3. Reihe links. / FutureSafe available as an option. If wheelchair in 2nd row, no tip & fold seat in 3rd row on the left.

**Achtung:** Die abgebildeten Varianten sind abhängig von Nutzlast und ZGG. Die gewünschte Sitzvariante bedarf der vorherigen Prüfung. Änderungen vorbehalten.  
**Caution:** Seating arrangements shown depend on payload and gross vehicle weight. The desired seating option requires prior approval. Subject to change without notice.



www.amf-brunns.de

02/2026 | Änderungen vorbehalten. / Subject to change without notice.

# KM PV5 Passenger



7-Sitzer/7-seater



51,5 kWh



≈ 2.730 kg





Rollstuhlgerechter Umbau von AMF-Brunns / WAV conversion by AMF-Brunns

## Originalboden/Original Floor

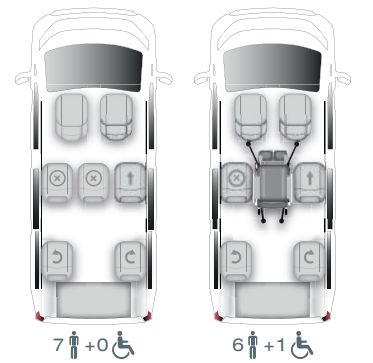
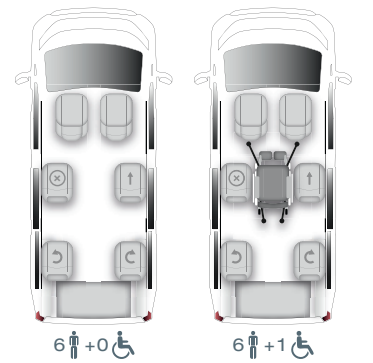
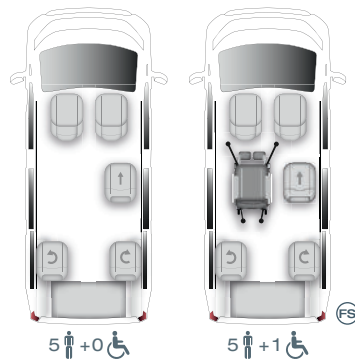
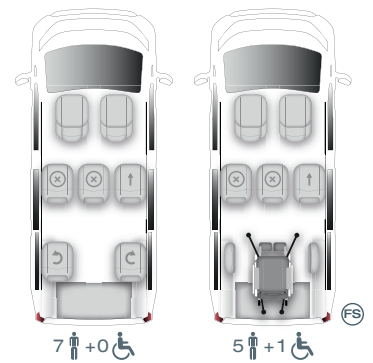
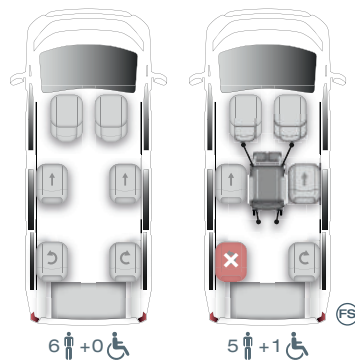
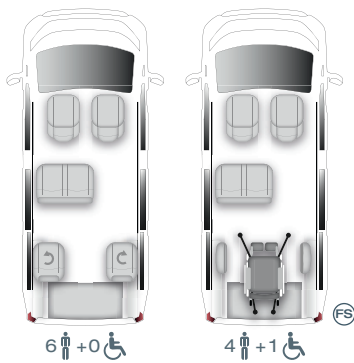
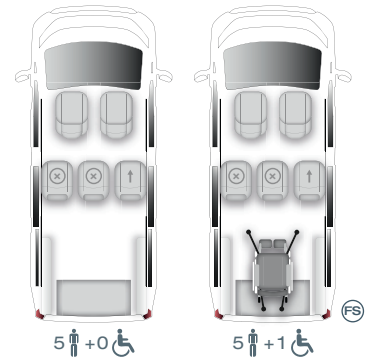
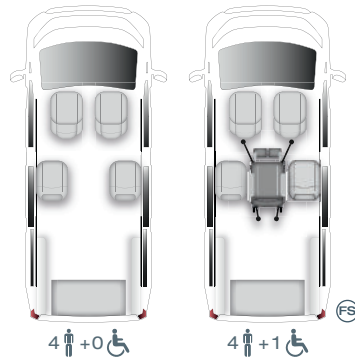
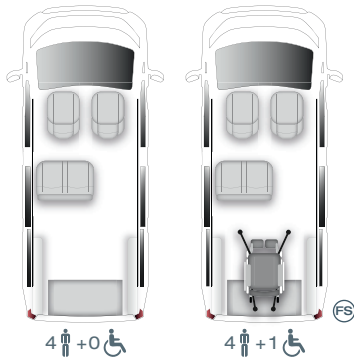
## Smartfloor Revolution

## Smartfloor



-  (Bei-)Fahrersitz / (Co-)driver's seat
-  Original 2er-Sitzbank / Original 2-seater bench
-  Klappbarer Einzelsitz / Foldable single seat
-  Dreh- und klappbarer Einzelsitz / Swivel and folding single seat
-  Herausnehmbarer Einzelsitz / Removable single seat

 Sitz darf bei Rollstuhlbeförderung nicht besetzt werden (abhängig von Nutzlast und ZGG) / Seat must not be occupied when transporting a wheelchair (depending on payload and gross vehicle weight).

 FutureSafe optional erhältlich. Wenn Rollstuhl in 2. Reihe, kein Dreh-Klappsitz in 3. Reihe links. / FutureSafe available as an option. If wheelchair in 2nd row, no tip & fold seat in 3rd row on the left.

**Achtung:** Die abgebildeten Varianten sind abhängig von Nutzlast und ZGG. Die gewünschte Sitzvariante bedarf der vorherigen Prüfung. Änderungen vorbehalten.  
**Caution:** Seating arrangements shown depend on payload and gross vehicle weight. The desired seating option requires prior approval. Subject to change without notice.



www.amf-brunns.de

# KM PV5 Passenger

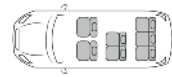

7-Sitzer/7-seater



71,2 kWh



≈ 2.730 kg

Rollstuhlgerechter Umbau von AMF-Bruns / WAV conversion by AMF-Bruns

## Originalboden/Original Floor

## Smartfloor Revolution

## Smartfloor

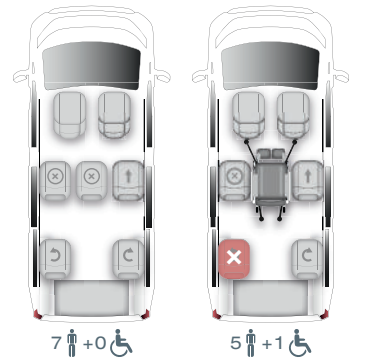
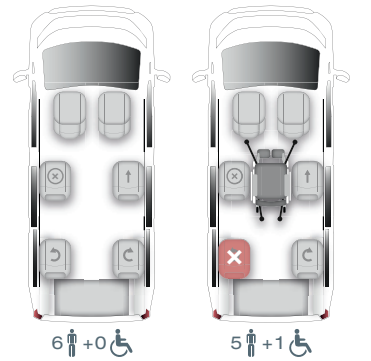
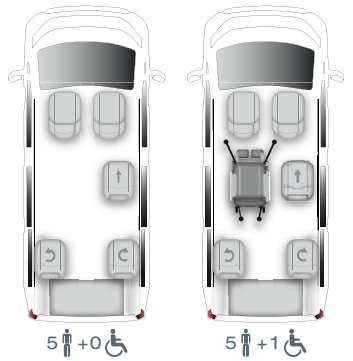
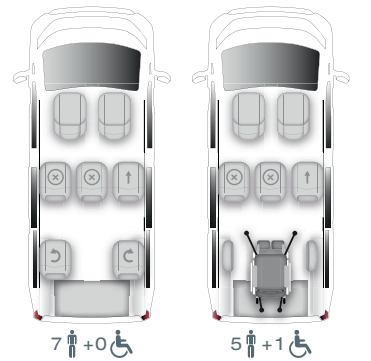
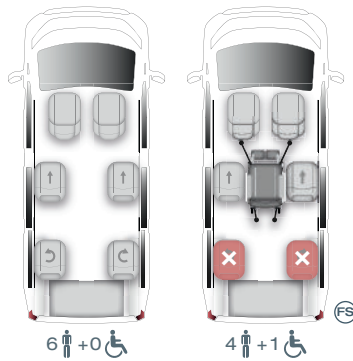
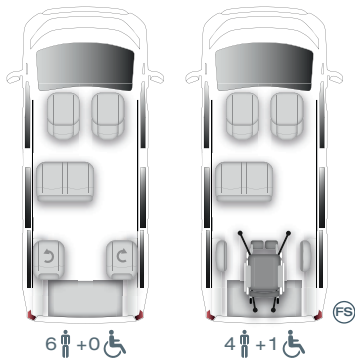
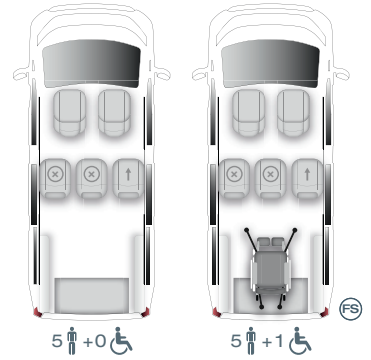
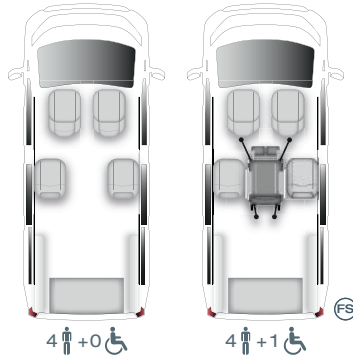
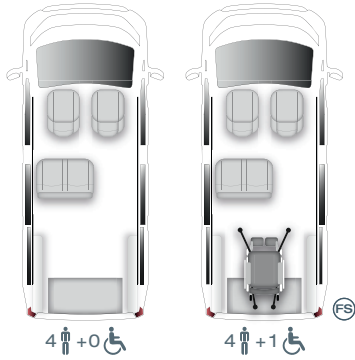

- (Bei-)Fahrsitz / (Co-)driver's seat
- Original 2er-Sitzbank / Original 2-seater bench
- Klappbarer Einzelsitz / Foldable single seat
- Dreh- und klappbarer Einzelsitz / Swivel and folding single seat
- Herausnehmbarer Einzelsitz / Removable single seat

Sitz darf bei Rollstuhlbeförderung nicht besetzt werden (abhängig von Nutzlast und ZGG) / Seat must not be occupied when transporting a wheelchair (depending on payload and gross vehicle weight).

FutureSafe optional erhältlich. Wenn Rollstuhl in 2. Reihe, kein Dreh-Klappsitz in 3. Reihe links. / FutureSafe available as an option. If wheelchair in 2nd row, no tip & fold seat in 3rd row on the left.

**Achtung:** Die abgebildeten Varianten sind abhängig von Nutzlast und ZGG. Die gewünschte Sitzvariante bedarf der vorherigen Prüfung. Änderungen vorbehalten.  
**Caution:** Seating arrangements shown depend on payload and gross vehicle weight. The desired seating option requires prior approval. Subject to change without notice.



www.amf-bruns.de